

# QUICK START UP PROCEDURE

(For Detailed Instructions - See User's Manual)

104494 Rev.A

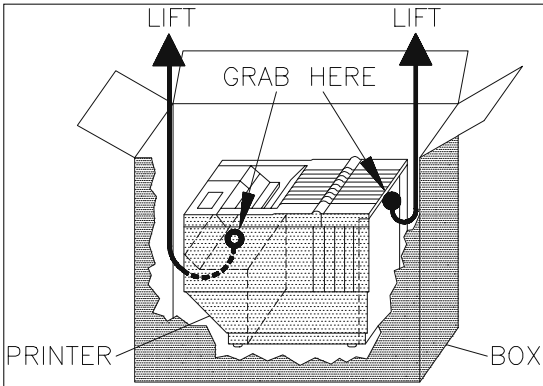

1. Remove top packing material.

2. Grab printer at midpoints indicated. Carefully lift printer from box and remove bag. **(CAUTION: Printer Weighs Approximately 45 lbs).**

3. **SAVE SHIPPING BOX AND PACKING MATERIALS!**

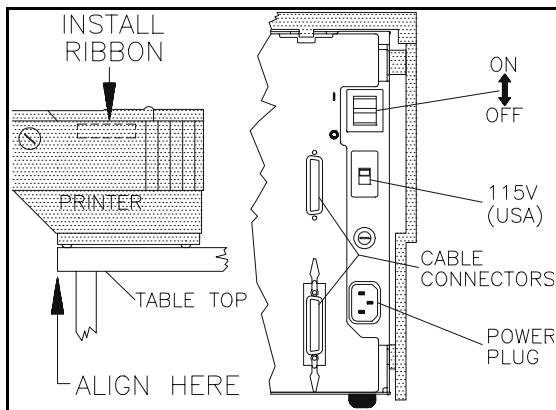

4. Install ribbon using instructions provided with ribbon box.

5. Align lower front of printer with table edge. (For improved forms loading and feeding, use the TG-DOC printer stand available from your distributor).

6. Attach appropriate communication cable from your computer.

7. If your model has a voltage selection switch, verify that voltage setting is correct (U.S.A. = 115V).

8. Attach power cord and turn power on.

9. Unlock right tractor and position for form width.

10. Equally space **ALL** paper guides and supports.

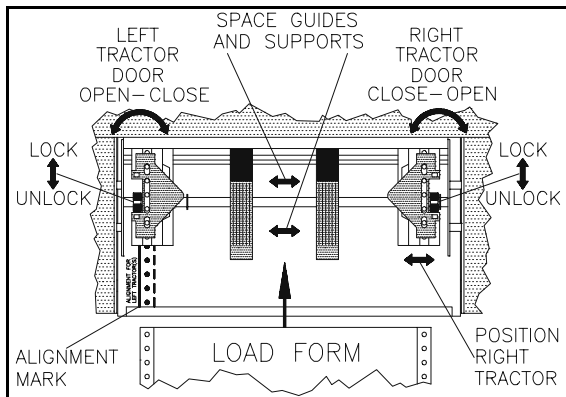

11. Open both tractor doors, load form, and close tractor doors.

12. Verify that left form edge is in line with alignment mark.

13. Adjust right tractor **SLIGHTLY** to remove slack in form and lock tractor. **(Do Not Over-Tension Form!)**

14. Forms should be positioned to feed straight, if not, reposition forms. (For dual path printers - see User's Manual).

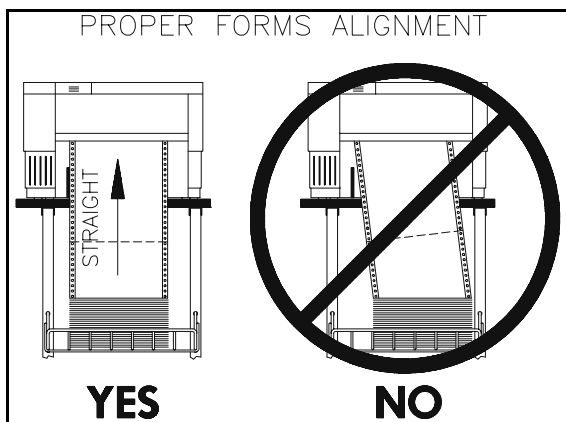

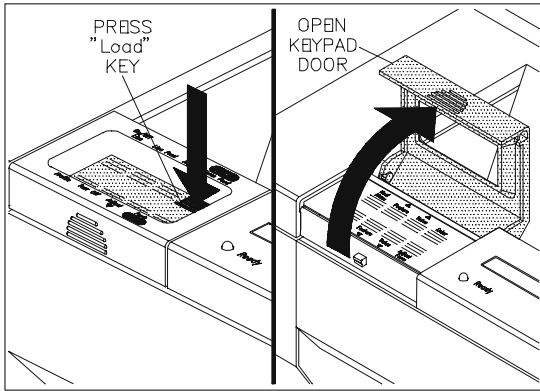

15. Load form by pressing "**Load**" key.
16. Open keypad door to access setup mode.
17. Press "**Adjust Form**" key.

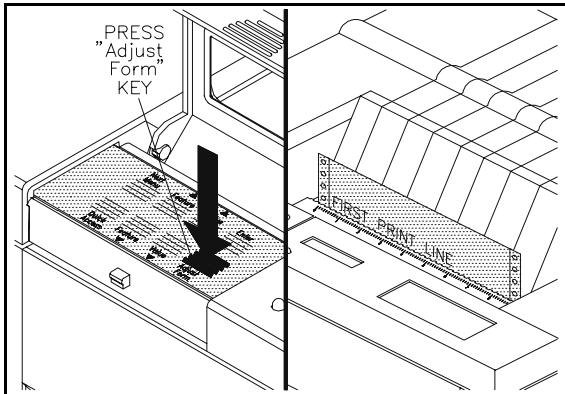

18. Use "**Value**" keys to position bottom of **FIRST PRINT LINE** to top of tear bar. Press "**Adjust Form**" key again.

19. (If your form is 9.5" x 11", go to step 24). Press "**Quick Access**" key until [**Form Length**] is displayed.

20. Use "**Value**" keys to set form length in number of lines. (**Example:** 3.5" long x 6 lines/inch[default] = 21). Press "**Enter**".

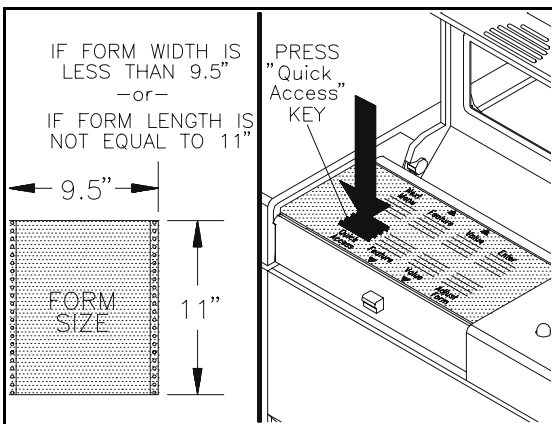

21. Press "**Quick Access**" key until [**Right Margin**] is displayed. (**WARNING: NEVER PRINT OFF EDGES OF FORM!**)

22. Use "**Value**" keys to set right margin position in number of characters. (**Example:** 6" wide x 10 char/inch[default] = 60). Press "**Enter**".

23. Close keypad door and press "**Profile**" key to save settings.

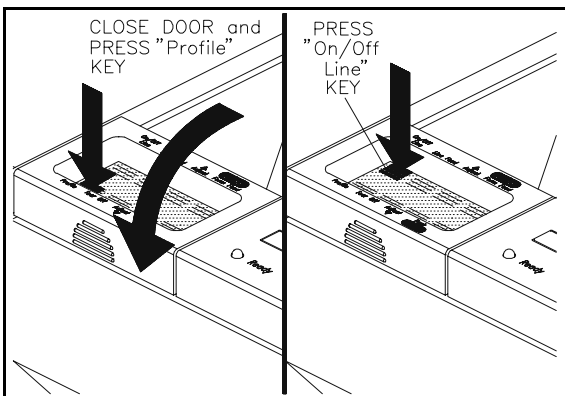

24. Press "**On/Off Line**" key to display [**On Line**] (Green light will remain on).

25. IF YOU TRY TO PRINT AND NO PRINTING OCCURS, open keypad door, press "**Next Menu**" key until [**M5 SERIAL CNTRL**] or [**M6 PARALLEL CTRL**] is displayed (for TX, CX, and Network models - see User's Manual). Use "**Feature**", "**Value**", and "**Enter**" keys to change settings. Repeat step 23 to save settings.

(For Detailed Instructions - See User's Manual)

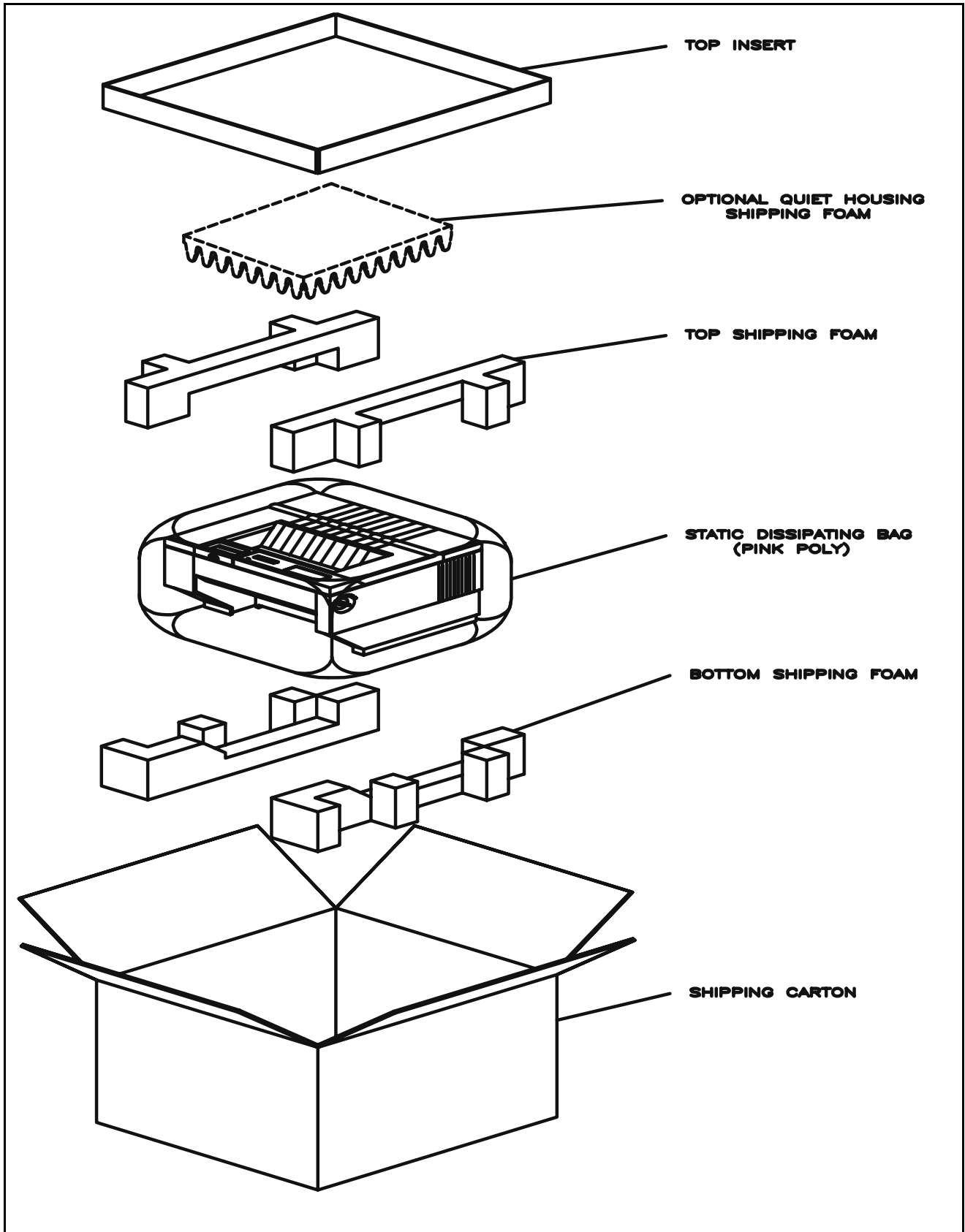

**REPACKAGING DIAGRAM**  
(Save Carton And All Shipping Materials)