

# CUT SHEET USER INSTRUCTIONS

(For Additional Instructions - See User's Manual)

BBF-104575 Rev.\*

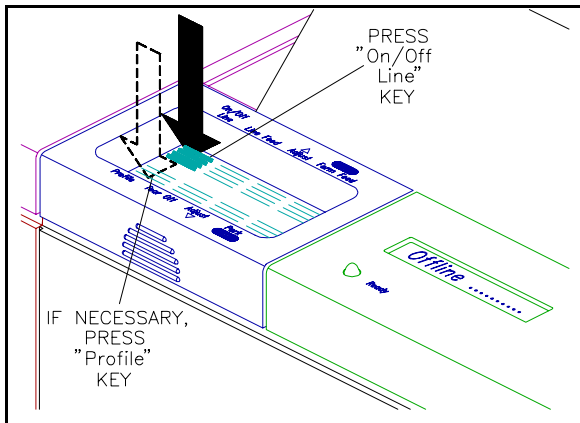

1. Execute QUICK START UP PROCEDURE (BBF-104494) before proceeding.

2. Press "**On/Off Line**" key until [**Offline .....**] is displayed.

3. If necessary, press "**Profile**" key to change to proper profile. (If desired, profiles can be customized. See User's Manual.)

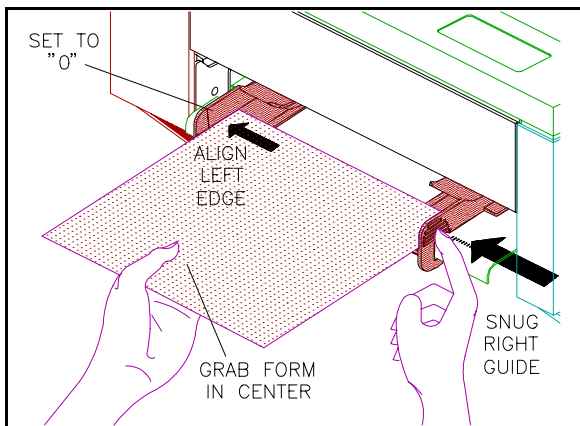

4. Set LEFT PAPER GUIDE window at the "0" mark.

5. Grab form in CENTER with one hand and align LEFT EDGE of form against LEFT PAPER GUIDE. (**Do Not Fully Insert Form.**)

6. Use other hand to snug RIGHT PAPER GUIDE against RIGHT EDGE of form. (**Do Not Buckle Form Between Paper Guides!**)

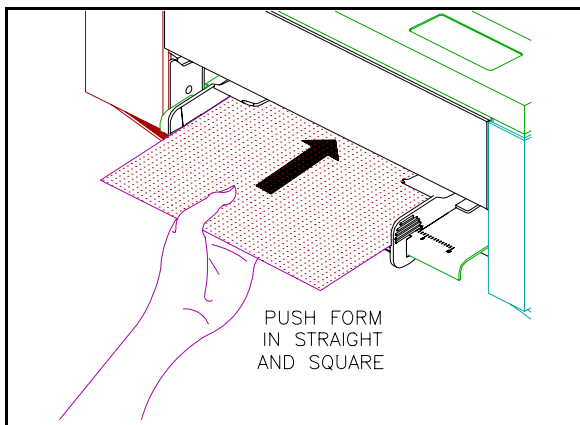

7. Push in form until LEADING EDGE is **SQUARE** and **STOPS**. (Care should be taken to keep form straight.) Printer will automatically LOAD FORM and go "**On Line**".

8. Form is now ready for printing.  
(**WARNING: NEVER PRINT OFF EDGES OF FORM!**)

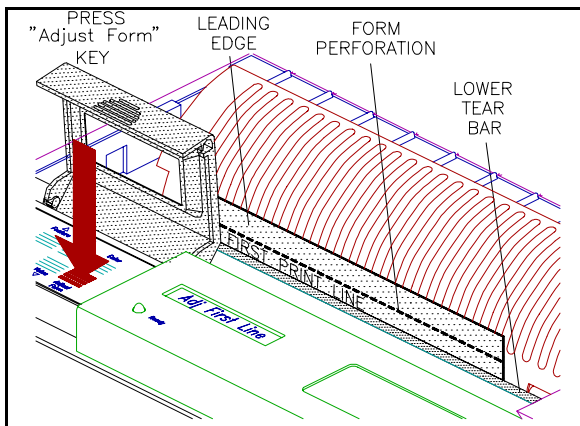

9. To readjust FIRST PRINT LINE (To compensate for a glued leading edge), open keypad door, and press "**Adjust Form**" key. Use "**Value**" keys to align bottom of FIRST PRINT LINE to top of tear bar. Close keypad door to save value.

10. To **EJECT** form for any reason, press "**Form Feed**" key.

# CUT SHEET TROUBLE-SHOOTING

(For Additional Instructions - See User's Manual)

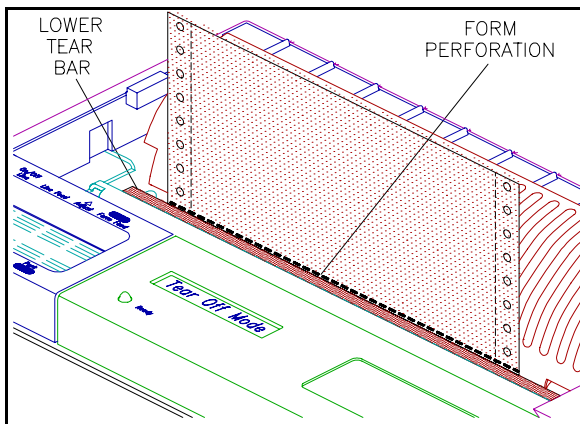
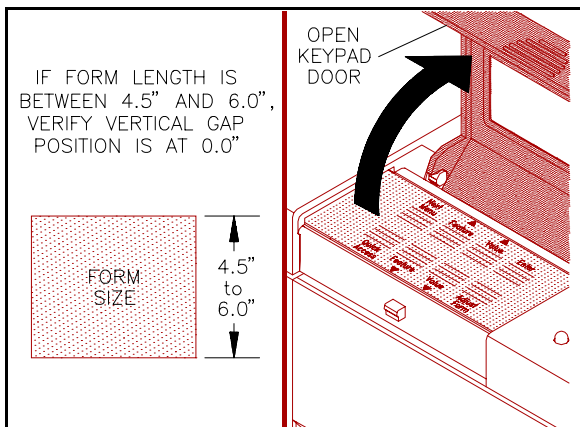
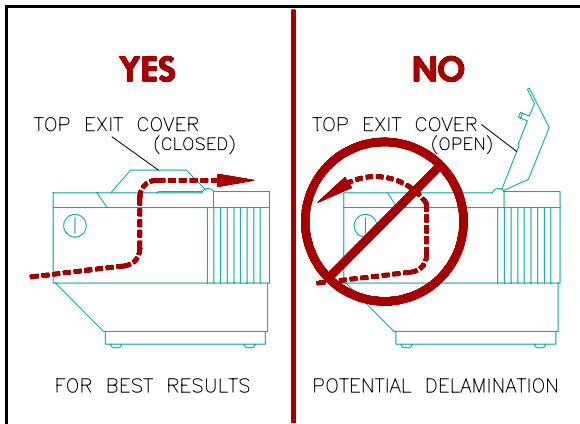
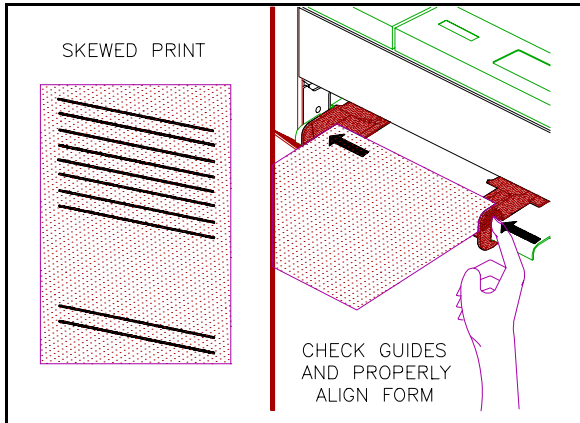

## 11. If print is skewed or angled:

- Make sure paper edge is against LEFT PAPER GUIDE.
- Properly snug RIGHT PAPER GUIDE against paper edge.

## 12. If print position on multi-part forms differs from first to last page (delamination):

- Keep TOP EXIT COVER closed while printing.
- Do NOT allow form to spill-over front of printer.

## 13. If skewing or delamination persists, slow paper speed:

- Open KEYPAD DOOR and press "Next Menu" key until [M2 FORMS CONTROL] is displayed.
- Use "Feature" down key to find [Paper Speed ..].
- Use "Value" down key to change to [Paper Speed 3].
- Press "Enter" key, close KEYPAD DOOR, and press "Profile" key to save setting.

## 14. If form is 4.5" to 6.0" long, verify vertical gap position:

- Open KEYPAD DOOR and press "Next Menu" key until [M8 FORM THICKNES] is displayed.
  - Use "Feature" down key to find [Vr Gap Pos x.x"].
  - Use "Value" down key to change to [Vr Gap Pos 0.0"].
  - Press "Enter" key, close KEYPAD DOOR, and press "Profile" key to save setting.
- (Failure to set vertical gap position to 0.0" for these forms may cause edge to catch under guide during form loading.)

## 15. If printer will not switch paths, change Path setting:

- Open KEYPAD DOOR and press "Next Menu" key until [M2 FORMS CONTROL] is displayed.
- Use "Feature" down key to find [Path .....].
- Use "Value" down key to change to [Path Either].
- Press "Enter" key, close KEYPAD DOOR, and press "Profile" key to save setting.

## 16. To avoid excessive opening and closing of TOP EXIT COVER (switching between tractor forms and very short cut sheet forms), change tear position:

- Set form length, "Load" tractor forms, press "Form Feed" key, then press "Tear Off" key.
- Use "Value" keys to change to [Tear 1 40/144"] or until **Perforation** is aligned with **Lower Tear Bar**.
- Press "Tear Off" key, press "Park" key, then press "Load" key to reset form for printing.