

QUIET OPTION QUICK START UP PROCEDURE

(For Detailed Instructions - See User's Manual)

BBF-104793 Rev.*

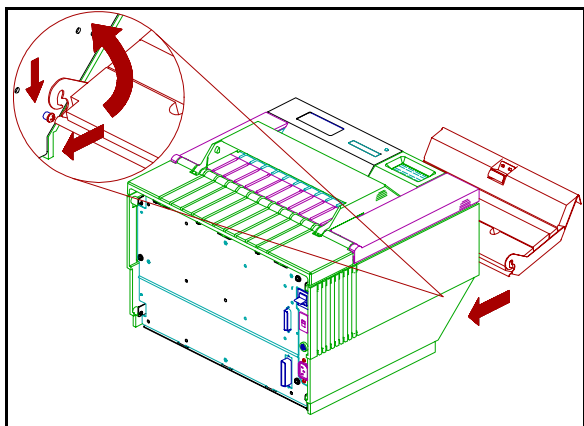
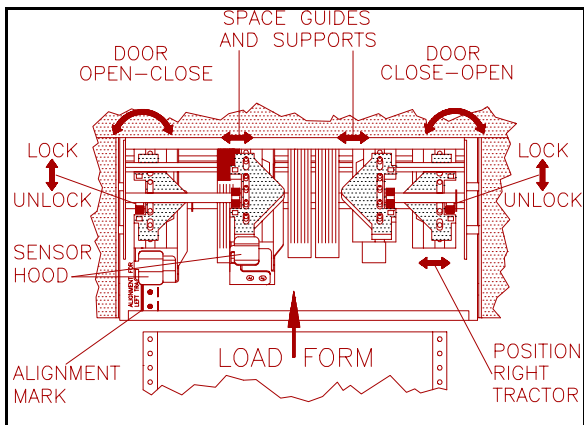
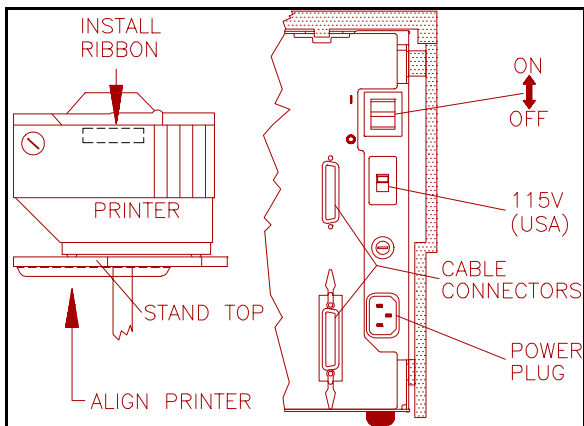
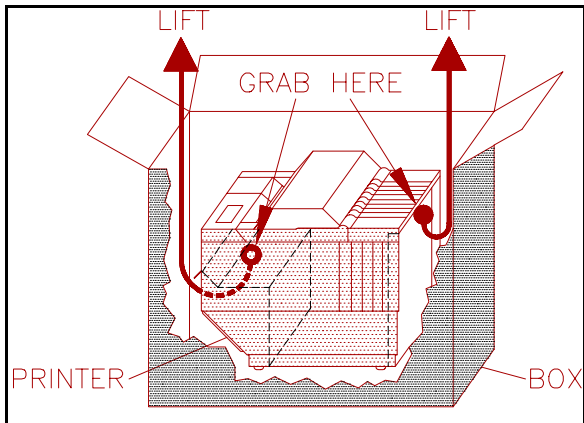

1. Remove top packing material and acoustic door. Place acoustic door to the side.
2. Using the midpoints as indicated, carefully lift printer from box and remove bag.

Printer Weighs Approximately 45 lbs.

3. **SAVE SHIPPING BOX AND PACKING MATERIALS!**
4. Install ribbon using instructions provided with ribbon box.
5. Align lower front of printer with table edge or place on printer stand. (For improved forms loading and feeding, use the TG-DOC printer stand available from your distributor).
6. Attach appropriate communication cable from your computer.
7. Verify correct voltage setting (U.S.A. = 115v).
8. Attach power cord and turn power on.
9. Load **Main Path** before attaching the Acoustic door.
10. Move alternate path tractors to center. Unlock right tractor and position for form width.
11. Equally space **Main Path** paper guides and supports.
12. Open both tractor doors, load form, and close tractor doors.
13. Verify that left form edge is in line with alignment mark.
14. Adjust right tractor **SLIGHTLY** to remove slack in form and lock tractor. (**Do Not Over-Tension Form!**)
15. Acoustic door **MUST** be attached to load the **Alternate Path**.
16. Attach front acoustic door by hooking over pivot points and leave open to rest on the table top or stand.

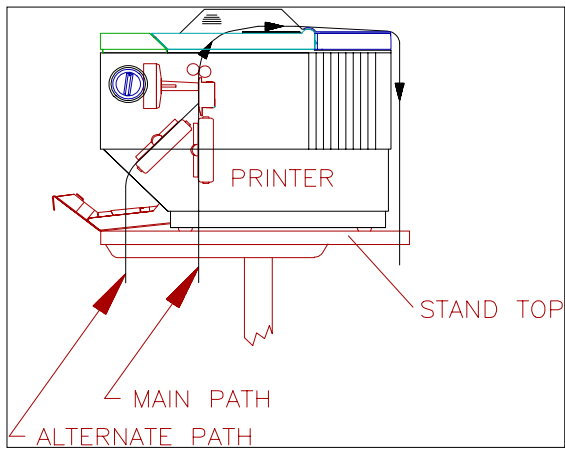

17. To load the **Alternate Path**, feed the paper through the slot in the door.

18. Load paper into the **Alternate Path** tractors following steps 10-14.

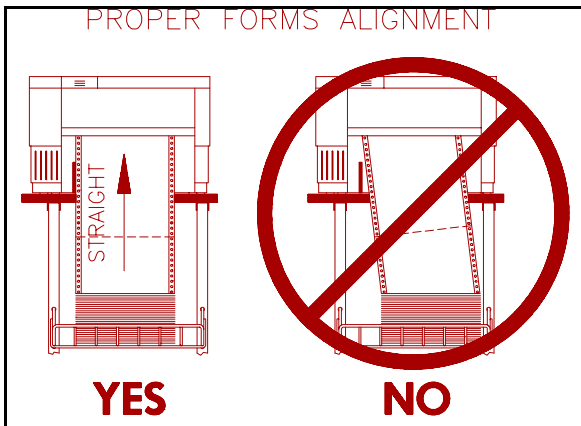

19. Forms should be positioned to feed straight, if not, reposition forms. (For dual path printers - see User's Manual).

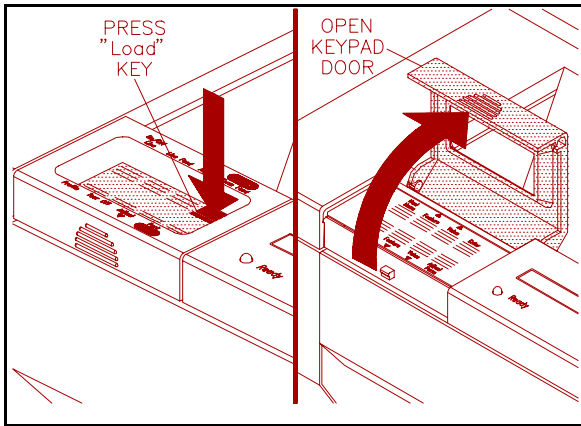

20. Press **Load** key to load form.

21. Open keypad door to access Setup Mode.

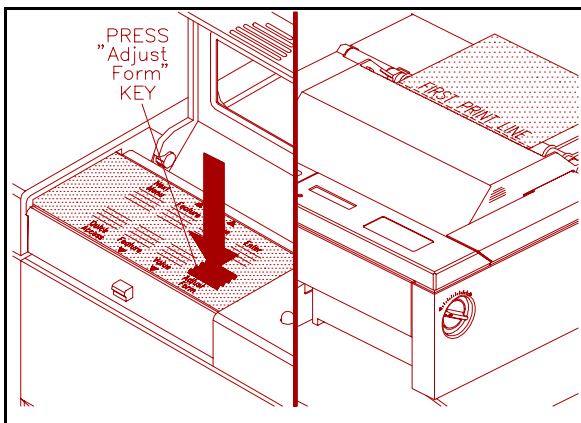

22. Press **Adjust Form** key.

23. Use **Value** keys to position bottom of **FIRST PRINT LINE** to the rear of top exit cover. Press **Adjust Form** key again.

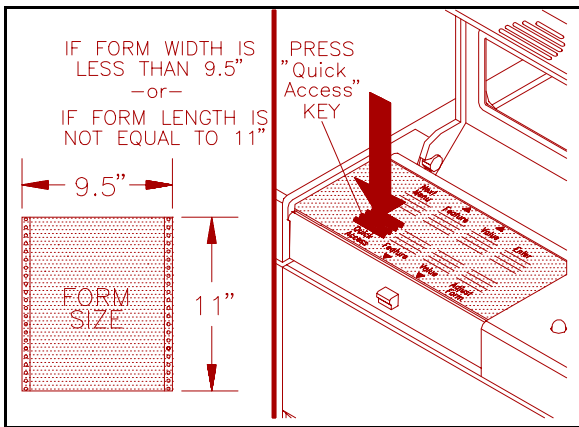

24. (If your form is 9.5" x 11", close keypad door and go to step 31). Press **Quick Access** key until "**Form Length 66**" is displayed.

25. Use **Value** keys to set form length in number of lines. (Example: 3.5" long x 6 lines/inch[default] = 21).

26. Press **Enter** key to save new value.

27. Press **Quick Access** key until "**Right Margin 80**" is displayed. (**CAUTION: NEVER PRINT OFF EDGES OF FORM!**)

28. Use **Value** keys to set right margin position in number of characters. (Example: 6" wide x 10 char/inch[default] = 60).

29. Press **Enter** key to save new value.

30. Close keypad door and press **Profile** key to save settings.

31. Press **On/Off Line** key to display "**On Line**" (Green light will remain on).

32. IF NO PRINTING OCCURS, open keypad door, press **Next Menu** key until "**M5 Serial Cntrl**" or "**M6 Parallel Ctrl**" is displayed. Use **Feature**, **Value**, and **Enter** keys to change settings. Repeat step 30 to save settings.

33. If QUIET MODE is desired, press **Next Menu** key until "**M8 Forms Thickness**" is displayed. Use **Feature** ∇ key until "**Quiet/LOW**" is displayed. "**Whisper/LOW**" will provide the lowest sound level possible; however print speed will be approximately 1/4 normal speed. Press the **Enter** key and close the door.

34. Press **Profile** to save your changes.

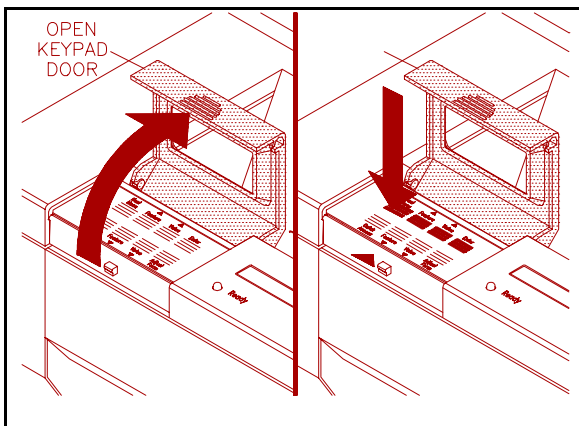
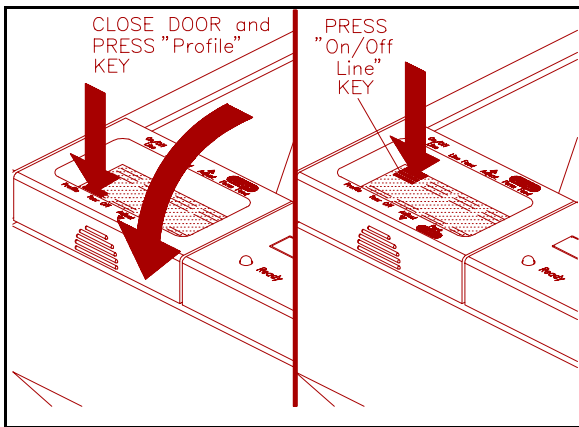

NOTE: "**Quiet/LOW**" impact is sufficient for most 1-2 part forms, the "**Quiet/MED**" setting is for 3-4 part forms and the "**Quiet/HI**" setting is for 5-9 part forms.

(For Detailed Instructions - See User's Manual)

REPACKAGING DIAGRAM

(Save Carton And All Shipping Materials)

