

# Quick Start Up Procedure (Journey II)

107245 Rev.\*

1. Unpack the printer using adequate assistance. Save packaging materials (for possible future reshipping).

2. Choose a location for the printer with the following considerations:

- A level surface capable of adequately supporting printer weight.
- Near a grounded power receptacle.
- Adequate clearance: Left side 3 inches (8 cm), Right side 11 inches (28 cm), Top 15 inches (38 cm), Back 3 inches (8 cm).
- Away from excessive illumination, high and low temperature and humidity, dirt and dust.

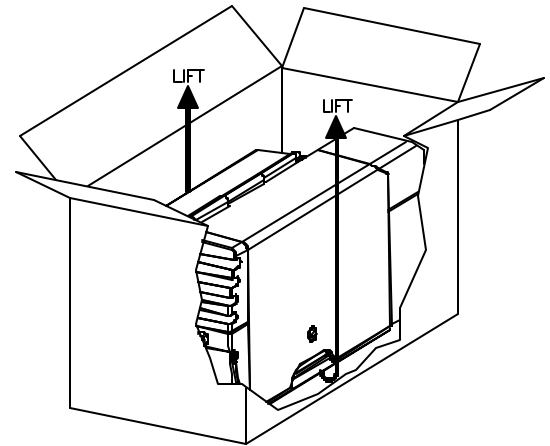

3. Align the front base of the printer with the desktop edge to allow the **Output BIN Door** to fully open and hang down out of the way. If the optional printer stand is used, align the rubber feet on the bottom of the printer with the holes on the top of the printer stand.

4. Connect and secure the host RS-232 serial connector to the printer's **COM1: INPUT** serial port located on the back of the printer (the bottom connector).

5. Connect a grounded AC power cord to an AC wall receptacle and the printer's **AC Power Cord Connector** located on the back of the printer.

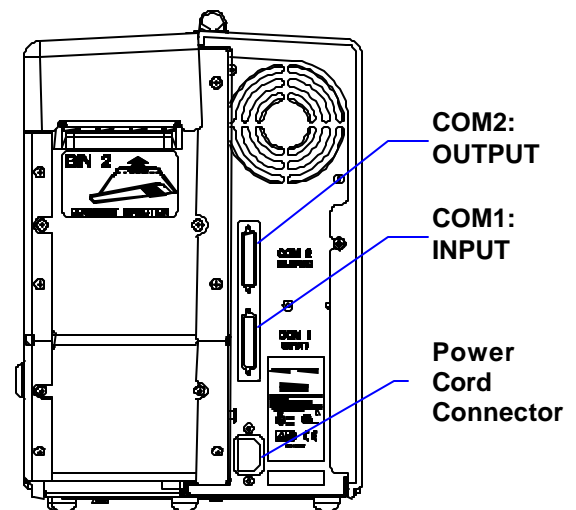

6. Using one of the keys provided, unlock the **BIN 1 Access Door** located on the right side of the printer.

7. Open the door completely until it rests on the left top side of the printer (as shown in the illustration).

**BIN 1 Access Door (Shown Open)**

8. Open a box of approved ATB coupon stock so that the staple tab is the leading edge and remove 500 coupons from the box (1/2 box). Place this stock in **BIN 1** as shown on the **BIN 1 Instruction Label**. *A maximum of 500 standard ATB coupons can be place in this BIN. Do not install coupons above the dotted line. Over-loading may result in ZONE 1 Jam errors.*

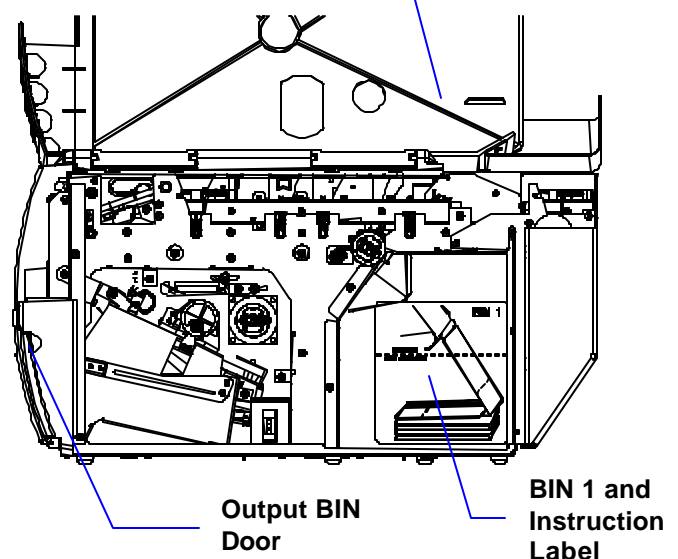

9. Gently square the coupon stack against the inside wall of **BIN 1**.
10. Insert the staple tab (with the print surface facing up) into the **BIN 1 Input Slot** (located at the top left corner of the BIN) until it is snug against the rollers.
11. Turn the green **Stock Load Knob A** one-quarter (1/4) turn counterclockwise to fully engage the staple tab in the load rollers.
12. Close and lock the **Bin 1 Access Door**.
13. Power the printer on using the power switch located on the left side near the back. Move the switch to the '1' position (towards the front) to turn on.
14. Wait for the power up self test to complete. The top line of the keypad display should indicate 'On Line:' when complete.
15. To load coupons into **BIN 2**, open another box of approved ATB coupon stock so that the staple tab is the leading edge. With the coupon box on the floor, align the box with the **BIN 2 Input Slot** located on the back of the printer (Note: **BIN 2** will accept a full 1000 coupon box).
16. Insert the staple tab (with the print surface facing up) into the **BIN 2 Input Slot** as shown on the **BIN 2 Instruction Label** (on back of printer). The printer will automatically load the coupons. (Note: *the printer must be powered on to load coupons into BIN 2*).
17. Press the **ON LINE/MENU** key to place the printer in Offline/Menu mode.
18. Press the **FEATURE ←** (left arrow) key until '**Print 1 Test Coupon**' appears in the keypad display. Press the **ENTER** key to print one test coupon.

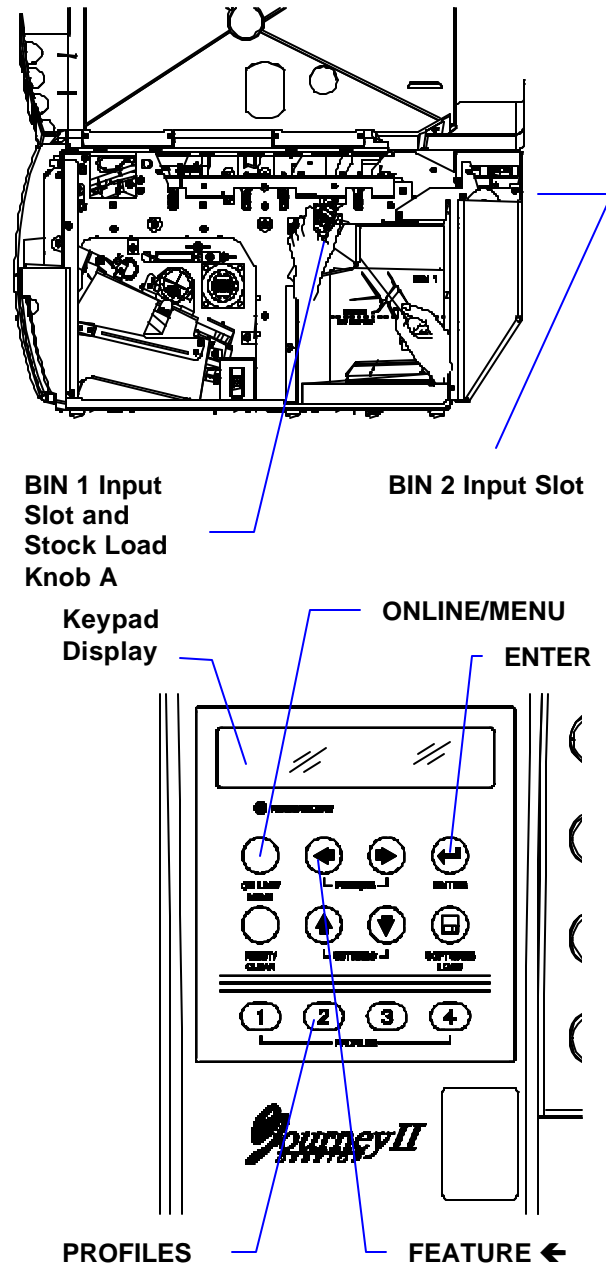

### **SETTING PROFILES:**

Selecting a Profile automatically sets all printer features to preset factory values for the intended application. **Select the correct Profile first before changing any other features** (such as Print Darkness, etc.) To select a Profile:

1. Press the **ON LINE/MENU** key to place the printer Off Line.
2. Press the **PROFILE 1, 2, 3** or **4** key for the preset profile that matches your intended application.
3. Press the **ENTER** key to activate and save the correct profile.
4. Press the **ON LINE/MENU** key to place the printer On Line.