

JOURNEY FEED MOTOR REPLACEMENT INSTRUCTIONS

Tools Required:

- No. 1 and No. 2 Phillips screwdrivers
- 5/32" Allen Wrench
- Wrist strap (or similar device) for ESD grounding

Feed Motor Replacement:

1. Verify that all replacement parts and tools are present.
2. Turn off the power switch, unplug the AC power cord, and disconnect all communication and interface cables.
3. Unlock and remove the Bin 1 Access Cover by rotating the cover to the 11 O'clock position and lifting it up and off. Remove eight #8-32 Phillips screws and the Service Cover from the mechanical frame.
4. **IMPORTANT: Properly ground yourself using an ESD wrist strap (or similar device) to prevent static discharge damage to the electronics.**
5. Remove the (2) Motor Shield Screws and remove the shield (Figure 1).
6. Disconnect all connections from main controller board assembly (Figure 2). Loosen the (4) main controller board Mounting Screws and remove the main controller board assembly.
7. Remove the feed motor cable from the wire restraints (Note: Removing the U-shaped solenoid bracket will make it easier to route the wires). Note the cable routing from the motor to the main controller board.
8. Remove (3) Motor Screws (Figure 3) and the feed motor.
9. Mount replacement feed motor (with wires exiting toward the front of printer) with (3) Motor Screws (**Note: Replace the top screw first**).
10. Route wires through Grommet (Figure 1) near Motor Shield and route through grommet (not shown) near output bin and behind U-shaped bracket. Restrain wires using existing wire clips.
11. Replace the main controller board and plug all connections to corresponding board locations (see tags for board locations). Restrain wires using existing wire clips.
12. Replace shield using the (2) Motor Shield Screws (and any other components that were removed).

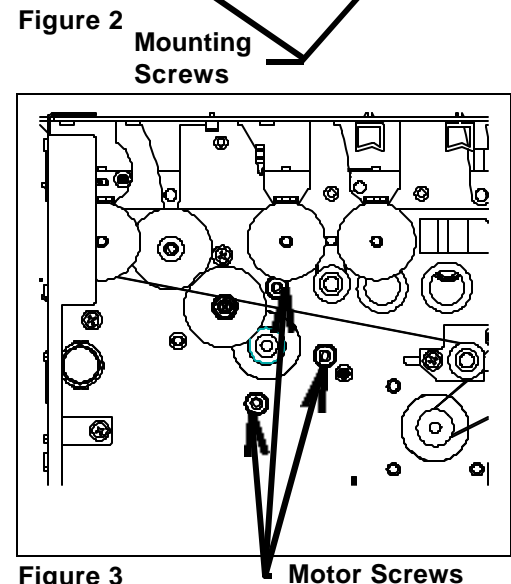
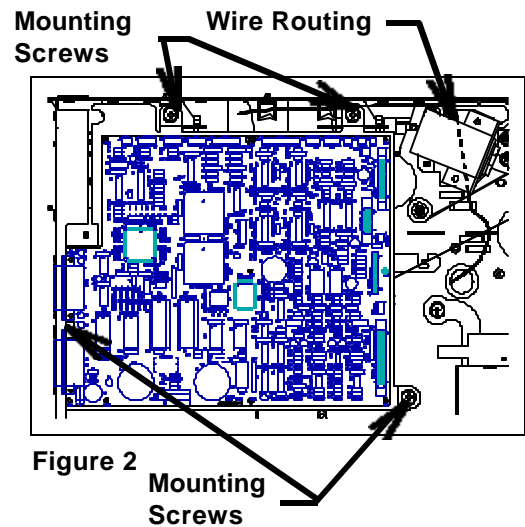
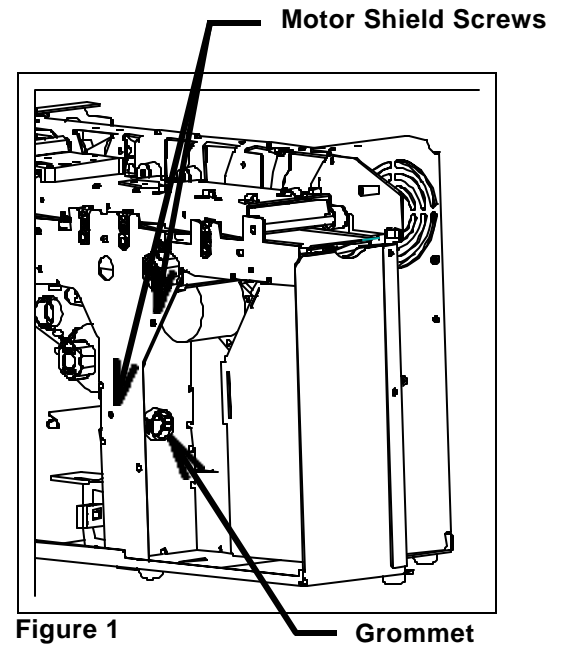

13. Replace both covers and close and lock the Bin 1 Access cover. Reconnect all communication and interface cables, plug in the AC power cord and turn on the power switch.
14. Verify proper functionality by printing a test coupon from Bin 1 (*refer to the Operations and/or Maintenance Manuals if you need additional information*).