

# ATB PRINTER BURSTER ASSEMBLY REPLACEMENT INSTRUCTIONS

107810 REV. A

## Burster Assembly Replacement

1. Turn power switch off disconnect AC plug.
2. Remove Bin 1 Access cover, (8) #8-32 screws, Service cover, and any loaded tickets.
3. Press lever in ZONE 1 and open top roller set. **Note: To prevent ESD damage to electronic components, be properly grounded when servicing main controller board.**
4. Unplug (19) connectors from main controller board, loosen (4) captive PCB panel screws, and remove main controller board assembly.
5. Remove (1) #8-32 pivot screw and remove pivot shaft, pivot spring, and top roller set. (Figures 1 and 2)
6. Remove (2) #8-32 mag-finger screws and finger assembly. (Figure 2)
7. Remove (2) #8-32 mag-channel screws, (1) #8-32 screw for the mag-head wire clamp and remove mag-channel assembly. (Figure 3)
8. Remove (4) #8-32 burster screws, lift burster module up and out, and replace with new module (make sure that gears are properly meshed). (Figures 1, 2, & 3).
9. Reverse procedures above to reinstall removed components.
10. Firmly close top roller set, replace both covers, connect AC plug and turn power switch on.

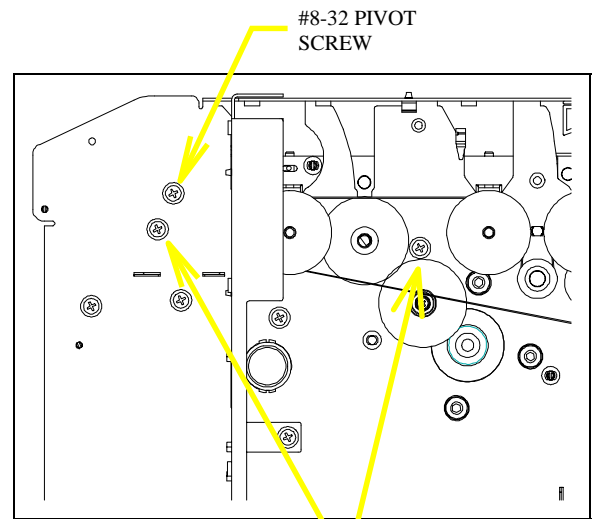

Figure 1  
#8-32  
FINGER

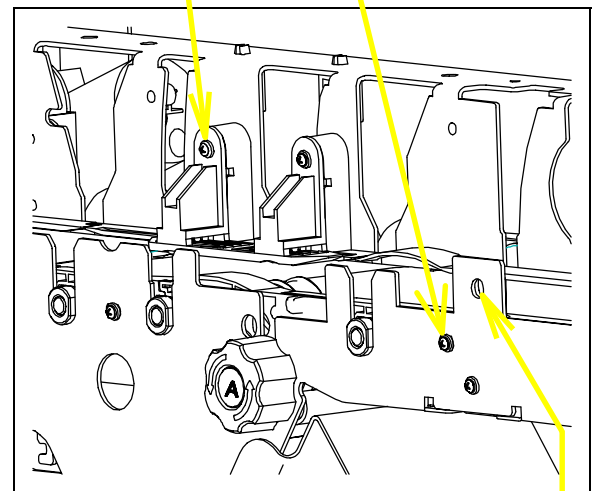

Figure 2

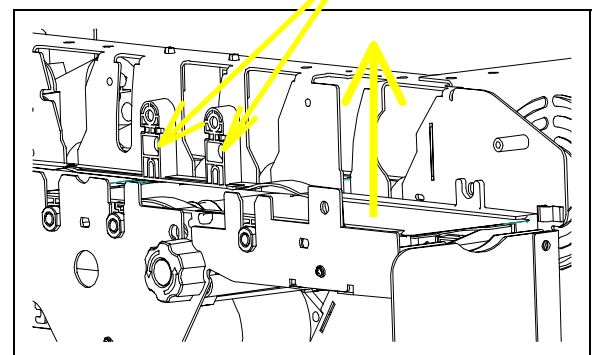

Figure 3

1. .