

## CODEWRITER 4510 PRINT HEAD REPLACEMENT INSTRUCTIONS

### Tools Required:

No.2 Phillips screwdriver, Slotted screwdriver, and wire cutters  
 Wrist strap (or similar device) for ESD grounding

### To Prepare the Printer for Maintenance

1. Verify that all replacement parts and tools are present.
2. Turn off the power switch, unplug the AC power cord, and disconnect all communication and interface cables.

3. Remove two M4 Phillips screws (1.1) from the left side panel of the printer (Fig.1 & 2).

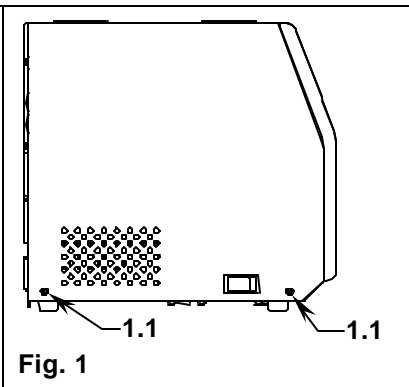

Fig. 1

4. Lift and rotate the right side panel until it rest on the top side of the left panel then remove three M4 Phillips screws (2.1) and the Cover Assembly from the printer chassis (Fig.2).

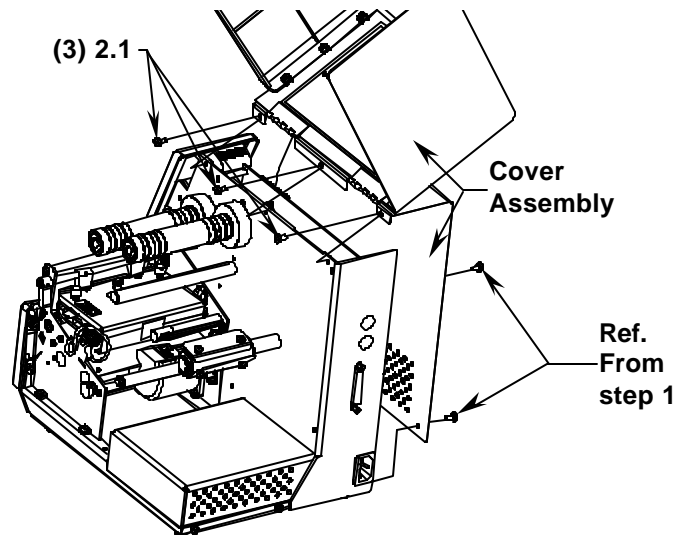

Fig. 2

## To Remove the Print Head Assembly:

**IMPORTANT:** Properly ground yourself using an ESD wrist strap (or similar device) to prevent static discharge damage to the electronics.

**IMPORTANT:** Note the routing and location of all connectors prior to disconnecting from the Main PCB Assembly.

5. Unplug all connectors from the Main PCB Assembly then remove two Female Screwlocks (3.1) located on the back panel, four M3 Phillips screws (3.2) and the Main PCB Assembly from the print chassis.

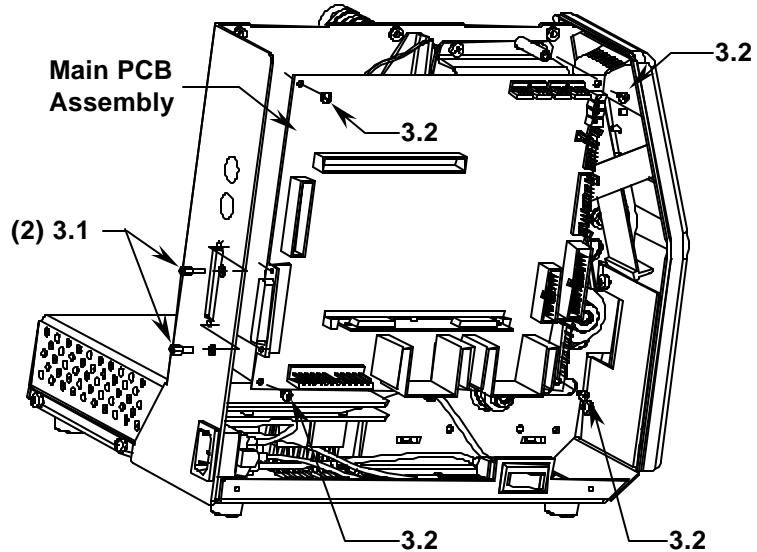

Fig. 3

6. Unfasten the Print Head Ribbon Cable from the large cable clamp then feed the cable through the clearance hole protected by the Nylon Grommet (4.1). Remove the M4 Phillips screw (4.2) that's securing one end of the Ground Wire and the left end of the Print Head Assembly Pivot Shaft.

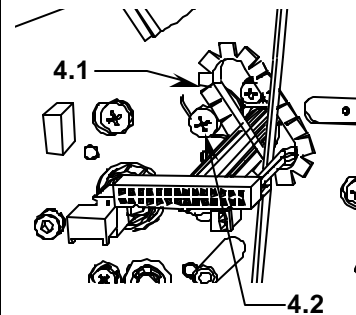

Fig. 4

7. From the right side of the printer, remove the M4 Phillips screw (5.1) and the Print Head Assembly (5.2) from the Paper-Path Chassis Assembly (5.3).

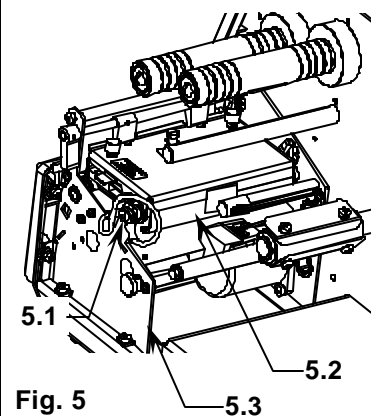

Fig. 5

8. Connect the six pin connector labeled HEAD from the Print Head Power Cable Assembly (6.1) to the six-pin header on the new Print Head (6.2) then from the right side of the printer, feed both cable assemblies from the Print Head Assembly through the clearance hole with the Nylon Grommet.

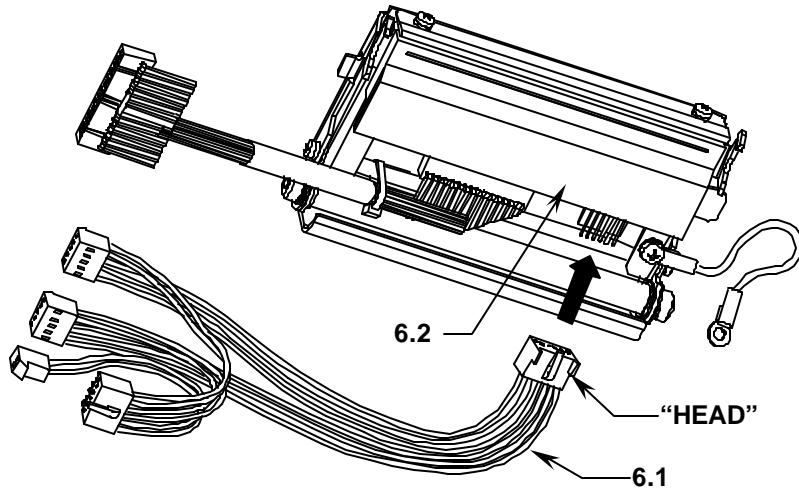

Fig. 6

9. Assemble the new Print Head Assembly (7.1) and the two Ground Wires to the Paper-Path Chassis Assembly with the two M4 Phillips screws from steps 6 and 7.

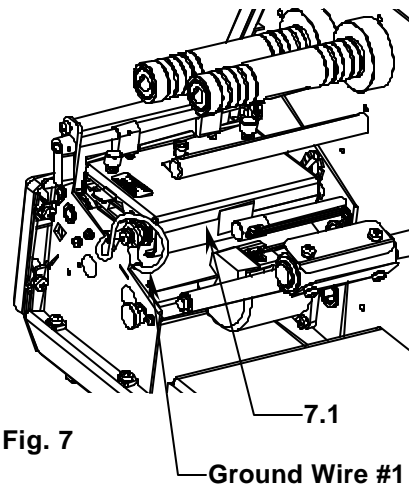

Fig. 7

10. Route the Print Head Ribbon and the Print Head Power Cables through the large Cable Clamp (8.1).

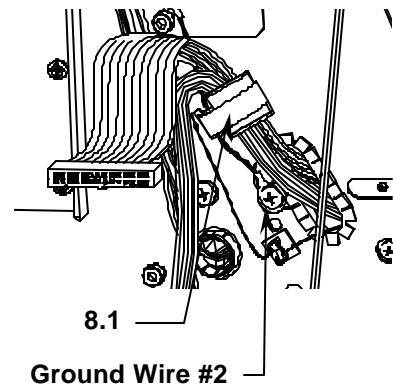

Fig. 8

11. Connect the Print Head Power Cable Connectors labeled PS CON 2, 3 and 4 to the appropriate headers on the Power Supply (9.1).

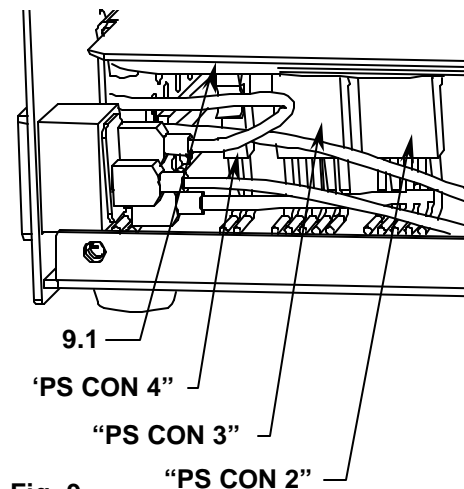
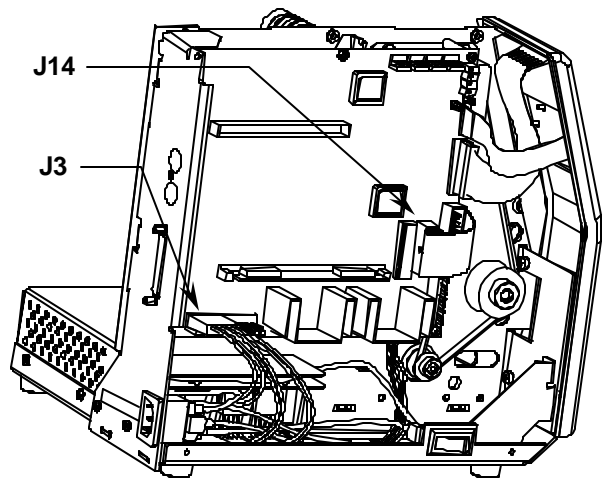

Fig. 9

**12.** Assemble the Main PCB Assembly to the printer chassis using the four M3 Phillips screws and two Female Screwlocks from step 5. Connect the Print Head Ribbon Cable to the J14 Header and the Print Head Power Cable connector labeled J3, to the J3 Header on the Main PCB Assembly. Connect the remaining cable assemblies to each assigned header on the Main PCB Assembly.



**Fig. 10**

- 13.** Check your work previously done, then secure the Cover Assembly to the printer chassis with the five M4 Phillips screws (see Fig.1 & 2).
- 15.** Reconnect all communication and interface cables, plug-in the AC power cord and turn on the power switch.
- 16.** Verify proper functionality by printing a test label (*refer to the Operations and/or Maintenance Manuals if you need additional information.*)