

# TP2000 PRINTHEAD CABLE ASSEMBLY REPLACEMENT INSTRUCTIONS

## Tools Required:

- No.1 and No.2 Phillips screwdrivers
- Wrist strap (or similar device) for ESD grounding

## To Replace the Printhead Cable Assembly:

1. Verify that all replacement parts and tools are present.
2. Turn off the power switch, unplug the AC power cord, and disconnect all communication and interface cables.
3. **IMPORTANT: Properly ground yourself using an ESD wrist strap (or similar device) to prevent static discharge damage to the electronics.**
4. Remove two #8-32 Phillips screws from the Top Cover, located in front on bottom side then lift and lock the Cover in place by pushing down the Locking Hinge Bracket, located on the left and inside of Base Assembly.
5. Loosen two #6-32 Phillips screws located on the top surface of the Front Stiffener Bracket then slid out the Printhead Cable Assembly from the each Retainer.
6. Remove three #8-32 Phillips screws on each side of the Front Stiffener Bracket then remove and place the bracket on the Base Assembly.
7. Remove two #4-40 Phillips screws from the Mounting-PH Clip, remove the clip from the Carriage and disconnect the Printhead Cable Assembly from the Printhead.
8. Remove two #8-32 Phillips screws from the Enclosure Door (located on backside of printer) and carefully open the door until it stops at a horizontal position then disconnect J2 connector on the Main Controller Assembly. **IMPORTANT: Notice the routing of the Printhead Cable Assembly prior to cable removal.**
9. Disconnect the Printhead Cable Assembly from the Printhead, remove and replace it with the new cable assembly and reroute.
10. Close and secure the Enclosure Door with the #8-32 Phillips screws from step 8 then reassemble all parts previously removed on printer in reverse order beginning with step 7.

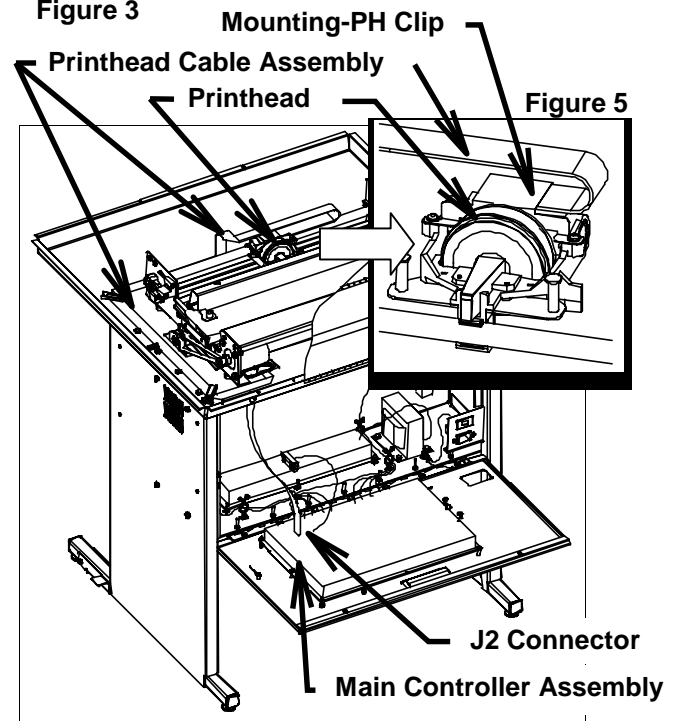
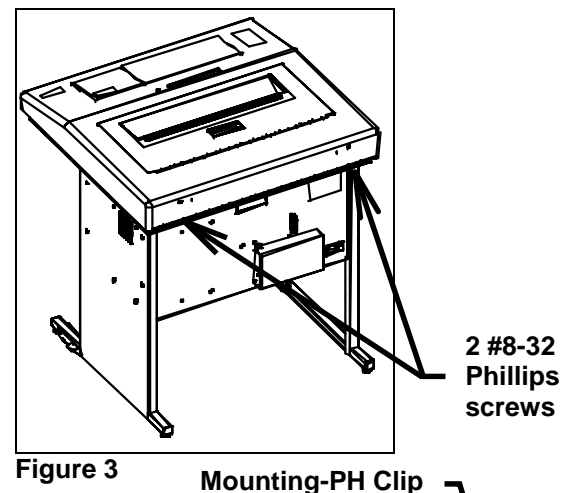
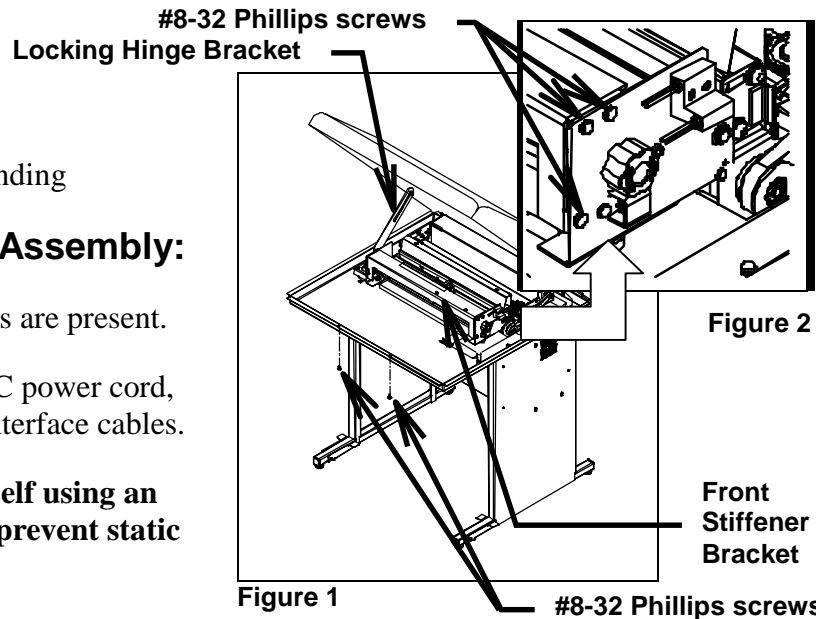

11. Unlock (pull up on Locking Hinge Bracket) and close the Top Cover then secure with two screws from step 4.
12. Reconnect all communication and interface cables, plug in the AC power cord and turn on the power switch.
13. Verify proper functionality by printing a self-test (*refer to the Operations and/or Maintenance Manuals if you need additional information*).