

TP2000 CARRIAGE MOTOR ASSEMBLY REPLACEMENT INSTRUCTIONS

Tools Required:

No.2 Phillips screwdriver and 5/32" Hex-Key wrench
Wrist strap (or similar device) for ESD grounding

To Replace the Carriage Motor Assembly:

1. Verify that all replacement parts and tools are present.
2. Turn off the power switch, unplug the AC power cord, and disconnect all communication and interface cables.
3. **IMPORTANT: Properly ground yourself using an ESD wrist strap (or similar device) to prevent static discharge damage to the electronics.**
4. Remove two #8-32 Phillips screws from the Enclosure Door (located on backside of printer) and carefully open the door until it stops at a horizontal position then disconnect J12 connector from the Main Controller Assembly.
5. Remove two #8-32 Phillips screws from the Top Cover, located in front on bottom side, then lift and lock the Cover in place by pushing down the Locking Hinge Bracket, located on the left and inside of Base Assembly.
6. Remove two #8-32 Phillips screws and the Carriage Motor Cover, located below the Carriage Motor, from the bottom side of the Base Assembly.
7. Remove the Carriage Drive Belt from the Carriage Motor by removing the Crown Roller while pushing in and holding the spring loaded Belt Tensioner Bracket, located on the Right Endplate Assembly.
8. Remove three 1/4-20 Button Head screws and the Carriage Motor Assembly from the Carriage Motor Bracket, located on the left Endplate Assembly. Lower the inside of the motors mount, flush with the top surface of the Base Assembly then rotate the motor 1/4 turn counter clockwise. Tilt the motor inward until the front mount corners are free from the clearance hole on base, and then carefully remove the motor assembly. **IMPORTANT: Notice the routing of the Carriage Motor cable prior to motor removal.**
9. Reverse step 8 to install the new Carriage Motor Assembly, reroute and connect the motor cable to J12 on

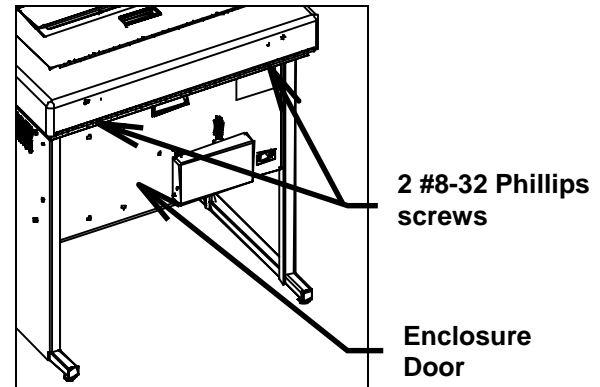

Figure 1

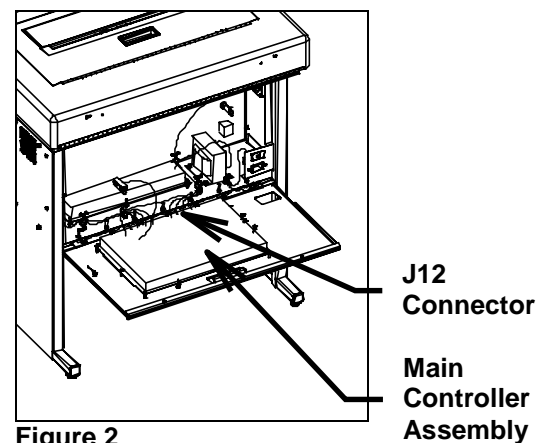

Figure 2

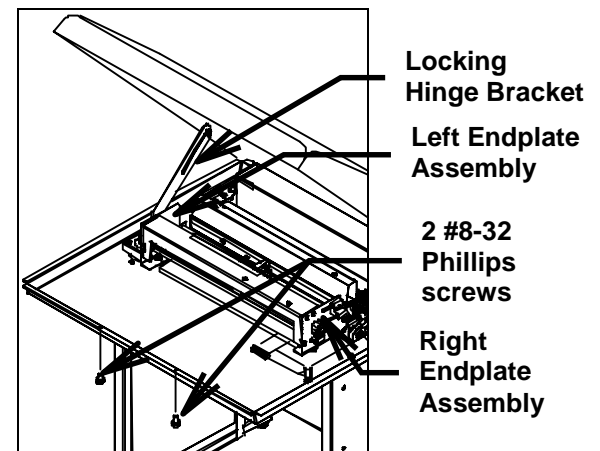

Figure 3

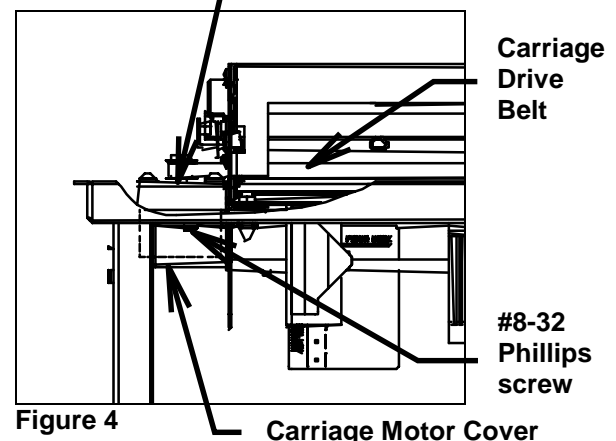

Figure 4

the Main Controller Assembly.

10. Install one end of the Carriage Motor Belt on the pulley of the new Carriage Motor Assembly then load the Crown Roller with the Tensioner Shaft vertical inside the other end of belt. Push the spring loaded Belt Tensioner Bracket in and slide the belt, roller, and the shaft inside the bracket.
11. Assemble the Carriage Motor Cover in its original location on the bottom side of the Base Assembly using the two #8-32 Phillips screws from step 6.
12. Close and secure the Enclosure Door with the two #8-32 Phillips screws from step 4.
13. Unlock (pull up on the Locking Hinge Bracket) and close the Top Cover then secure with the two #8-32 Phillips screws from step 5.
14. Reconnect all communication and interface cables, plug in the AC power cord and turn on the power switch.
15. Verify proper functionality by printing a self-test (*refer to the Operations and/or Maintenance Manuals if you need additional information*).

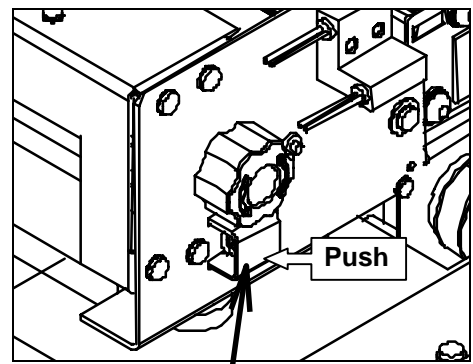

Figure 5

Belt Tensioner Bracket

Left Endplate Assembly

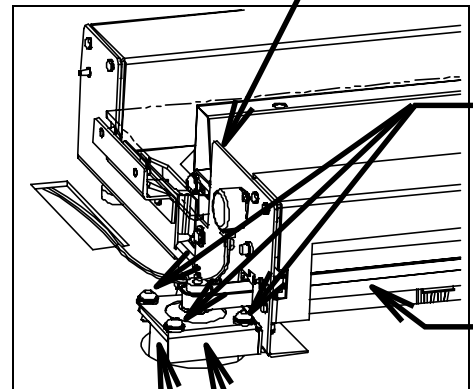

Figure 6

Carriage Motor Bracket

Carriage Motor Assembly

3 1/4-20 Button Head screws

Carriage Drive Belt