

# SIGMA DATA 7200 MAIN PCB ASSEMBLY REPLACEMENT INSTRUCTIONS

## Tools Required:

- No.2 Phillips screwdriver
- Wrist strap (or similar device) for ESD grounding

## To Prepare the Printer for Maintenance:

1. Verify that all replacement parts and tools are present.
2. Turn off the power switch, unplug the AC power cord, and disconnect all communication and interface cables.

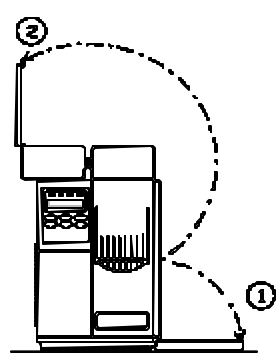
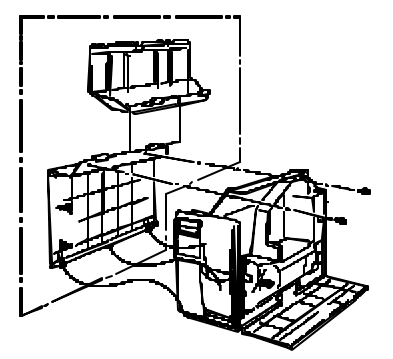
<ol style="list-style-type: none"> <li>3. (1) Unlock and open the Lower Right Side Cover then (2) open the Upper Right Side Cover completely, until it rest on the Service Cover (Fig.1).</li> <li>4. Remove the Service Cover by removing the two M3 Phillips screws holding the Service Cover to the upper frame of the printer (Fig. 2).</li> </ol>	 <p>Fig. 1</p>	 <p>Fig. 2</p>
--------------------------------------------------------------------------------------------------------------------------------------------------------------------------------------------------------------------------------------------------------------------------------------------------------------------------------------------------------	--------------------------------------------------------------------------------------------------	---------------------------------------------------------------------------------------------------

## To Replace the Main PCB Assembly:

**IMPORTANT:** Properly ground yourself using an ESD wrist strap (or similar device) to prevent static discharge damage to the electronics.

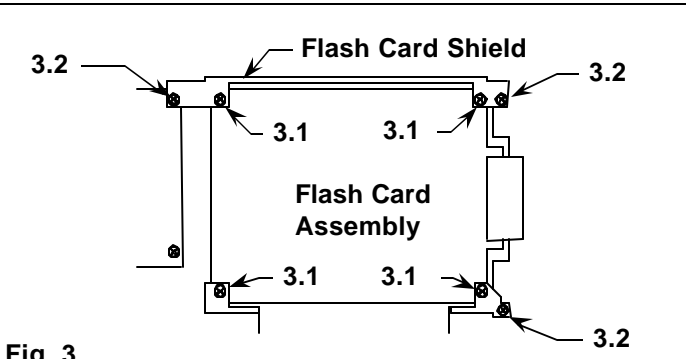
<ol style="list-style-type: none"> <li>5. Remove four M3 Phillips tapping screws [3.1] from the Flash Card Assembly. Remove the three M3 Phillips tapping screws [3.2] located in the corners of the Flash Card Shield then disconnect the Flash Card Assembly from the Main PCB Assembly.</li> </ol>	 <p>Fig. 3</p>
-------------------------------------------------------------------------------------------------------------------------------------------------------------------------------------------------------------------------------------------------------------------------------------------------------	----------------------------------------------------------------------------------------------------

6. Disconnect all connectors from the Main PCB Assembly.
7. Remove the M3 Phillips tapping screw [4.3] and the BCR Guide [4.4], located below the Main PCB Assembly [4.5] and on the base of the printer chassis.
8. Remove three remaining M3 Phillips tapping screws [4.6]. Then remove the Main PCB Assembly from the printer.
9. Slide the left end of the new Main PCB Assembly between the Flash Card Shield and the two molded plastic standoffs. Align the connector holes on the new Main PCB Assembly with the four Connector Guide Pins [4.7]. Then carefully push in the new PCB Assembly until it is completely seated on both connectors and all of the plastic standoffs.

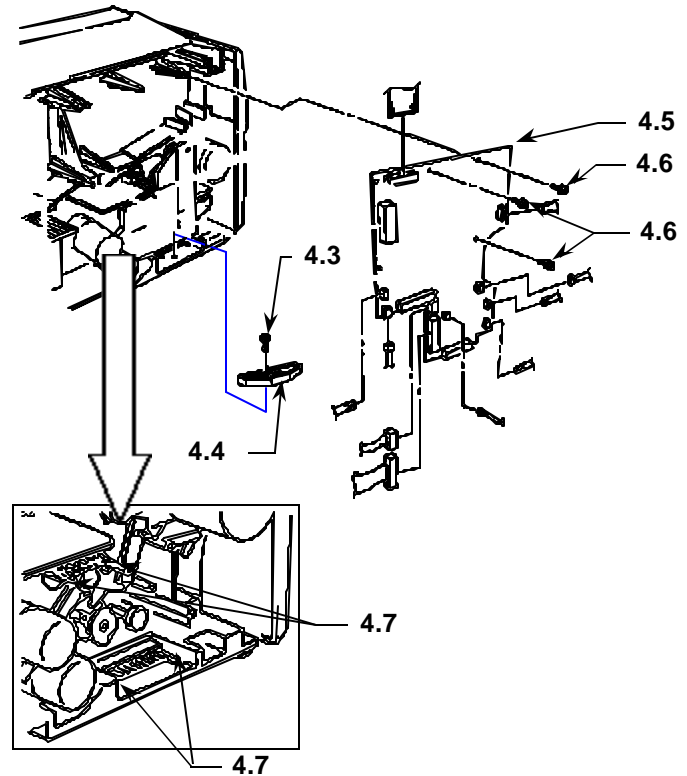

Fig. 4

10. Assemble all parts previously removed in reverse order.
11. Close the Upper Right Side Cover, then close and lock the Lower Right Side Cover.
12. Reconnect all communication and interface cables, plug-in the AC power cord and turn on the power switch.
13. Verify proper functionality by printing a test coupon (*refer to the Operations and/or Maintenance Manuals if you need additional information*).

### Installation Verification

1. Power on the printer.
2. Print a coupon sample using the *ATB2 Print* test.

1. Enter into Test mode.	Test Print
2. Press the Enter button	ATB2 Print
3. Press the Enter key. The F will be flashing.	STK NBR F **
4. Use the UP-Down arrow buttons to select the path where the printed sample will be pulled from, then press the ENTER button.	
5. Examine the printed coupon.	
6. Exit Test Mode.	

3. *Tips:* If the printer powers up and the coupons only move one direction and immediately goes to the online display, verify that the encoder cable (S11) is connected.